

LABORATORY HOOD/CABINET IDENTIFICATION AND USE

(For assistance, please contact EHS at (402) 472-4925, or visit our web site at <http://ehs.unl.edu/>)

Laboratories may contain more than one type of local ventilation system. Each type has been designed for a specific use. It is important to understand how these systems operate and their limitations. Use of the incorrect hood/cabinet or incorrect use of a hood/cabinet will put the user and others at risk of exposure. This SOP identifies the most common types of specialized laboratory local ventilation systems and addresses the correct use and operation of each. To ensure hoods/cabinets are working as designed all types are inspected annually by UNL Facilities Management and Planning. FMP personnel will apply a sticker to the cabinet, which identifies the last date of inspection.

Chemical Fume Hoods

Chemical fume hoods are designed to protect the worker from chemical exposure. Air is pulled into the face of the hood and exits through a stack that exhausts to the outside of the building. The outgoing airflow moves aerosols, fumes, and vapors away from the worker. Constant volume chemical fume hoods exhaust a constant supply of air regardless of sash height. When the sash of a constant volume chemical fume hood is fully raised, the face velocity decreases because the same amount of air is being drawn through a larger space.

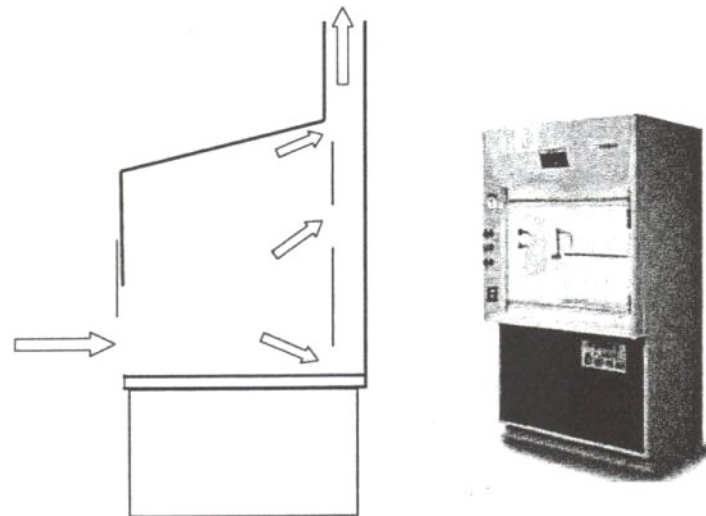

Chemical Fume Hood

Variable air volume hoods are equipped with controls that adjust the volume of supply and exhaust air to maintain the set face velocity regardless of sash height. Regardless of the type of chemical fume hood, proper use and operation is critical to worker protection. The capture efficiency of a hood can be severely impaired by room and use factors.

- Read and adhere to all manufacturer recommendations/guidelines.

- Understand how the fume hood monitor and controls work and the information that is being displayed. Controls that have been manufactured at UNL are installed on many fume hoods.
 - When using the fume hood, activate the black button. The green light should shine steadily to show normal flow and the digital numerical display should read the face velocity. The measured face velocity should be within 10% or so of the face velocity recorded on the most recent fume hood calibration/inspection sticker. If the face velocity does not read a flow or the flow is not consistent with the number recorded for the latest validation, do not use the fume hood and call in a service request.
 - When the fume hood is idle (no air contaminants being generated within), it should be put in the standby mode to reduce the amount of energy being consumed. To place the fume hood in a standby mode, activate the black button again. When in the standby mode, the light will flash. NEVER conduct operations in the fume hood while it is in the standby mode.
 - The red button is termed an emergency button. When this button is activated, the amount of air being exhausted is maximized. This button is intended for situations where there is a chemical spill outside or inside the fume hood. Do not operate the fume hood in the emergency mode under normal use conditions. The increased ventilation rate could compromise the capture efficiency of the hood, meaning air contaminants could “spill out” of the hood rather than being exhausted due to the increased air turbulence.
 - The grey button is a mute button for the alarm, which is activated when the face velocity of the hood is below the set point, indicating insufficient capture efficiency. The alarm is also activated when the hood is placed in the emergency mode. Most often the alarm will activate when the sash is raised high resulting in a lowering of face velocity. Only activate the mute button when you know WHY the alarm is activated and the condition is corrected.
 - If your fume hood is not equipped with a UNL-manufactured monitor/controller, follow the directions provided by the manufacturer.



- Some laboratories at UNL have also been equipped with general ventilation controls in an effort to reduce energy costs. It is important that you understand how this controller works and what it does.

- When working in the laboratory or active processes are occurring in the laboratory that may result in air borne contaminants (fugitive emissions), be sure that the “Start” button has been activated on the general ventilation control. The green LED will illuminate. IF the light is not illuminated, do not begin work in the laboratory that may generate airborne contaminants. If the control appears to be malfunctioning, call the UNL Service Desk and do not conduct activities in the laboratory that could generate airborne contaminants, unless conducted only in a properly functioning fume hood.



- When the laboratory is idle and there is little to no potential for airborne contaminants, activate the “Stop” button. This will reduce the number of air exchanges in the room as a means of conserving energy. However, remember to activate the “Start” button upon resuming activities in the laboratory that could result in airborne contaminants.

- Call the Service Desk and refrain from using a fume hood that:
 - Has been clearly labeled as out-of-service
 - Is not in the proper normal operating mode (as described above),
 - Is in an alarm or emergency state
 - Has a malfunctioning monitor
 - Has a noticeable lack of air flow,
 - Is allowing odors to escape into the laboratory
- Keep ignition sources outside of the hood when using flammable materials within.
- To ensure adequate containment of vapors, position all work and equipment at least 6 to 8 inches behind the fume hood sash/opening. Vapors and other contaminants can “spill out” of the hood if the generating activity is placed closer than 6” to the sash opening.
- Keep the sash in the lowest possible position while working in the hood; close the sash when not immediately working in the hood. Vapors and other contaminants are contained in the hood with greater efficiency at lower sash heights. In addition, the sash provides protection from splash and other adverse conditions (e.g., fires, implosions, etc.).
- The airfoil below the sash and the baffles at the back of the fume hood are critical to effective air flow and the containment efficiency of the hood. Be sure to keep

these areas clear. Do not block them with equipment, paper towels, absorbent pads, etc. Do not adjust hood baffles.

- Minimize foot traffic in front of hoods while chemical operations are in process, particularly if the sash is not fully closed. The air current created when walking past a fume is at least 2x the typical face velocity of air entering the hood, thus momentarily causing “spill out” from the hood. Spill out can also occur as you create air currents when walking away from a hood, making it important to close the sash before you walk away.
- Place hands and arms into a fume hood only when absolutely necessary, and then use slow movements to avoid creating unnecessary air turbulence within the hood. Do not place your head in the fume hood.
- When moving the sash up or down, use slow and deliberate motions to minimize air turbulence and the potential for “spill out.”
- Keep items in the fume hood to an absolute minimum and only that which is immediately necessary. Items within the fume hood will impede air flow and compromise capture efficiency. Large items will typically need to be elevated so air can flow underneath and around the item. If air flow is blocked, it may ricochet off the item and “spill out” will occur.
- Open windows and nearby fans or other sources of air turbulence can also negatively impact fume hood performance.
- Do not compromise the structural integrity of the hood by drilling holes into the side walls, removing sash pieces or other equipment, etc.
- Consider a glove box when handling materials that have occupational exposure limits in the low parts per billion range or are otherwise considered highly hazardous.
- When selecting a location for fume hood installation, select low traffic areas, away from doors, and a proper distance from room supply air diffusers to minimize turbulence that can pull fumes out of the hood. Consider perforated air diffusers to minimize high velocity directional supply air in the vicinity of fume hoods.
- Do not use fume hoods as general storage locations for chemicals or equipment (with the exception of highly toxic, pyrophoric, and corrosive gases which must be stored and used in a ventilated cabinet).
- When no processes are being conducted in the fume hood, activate the energy saving UNL-manufactured controller as described above. If your fume hood is only equipped with an on/off switch, shut-off the exhaust fan and close the sash. However, observe the following conditions and precautions when shutting off a fume hood:
 - Conditions:
 - General room exhaust must be maintained.
 - General room exhaust must be sufficient to maintain a negative air balance in the laboratory relative to adjacent corridors.
 - Precautions
 - Remove chemicals that present physical and health hazards from the hood and store safely and in their designated storage location.

- If any chemicals remain in the hood, they must be of absolute minimum quantities, stored in a tightly closed container, and in observance of chemical compatibility considerations with respect to other materials in the cabinet.
 - If the hood is being used for storage of chemicals because it is the most appropriate safe location (i.e., lecture sized cylinders of toxic gases, stench agents, etc.), do not shut off the ventilation at any time
- Radioisotope and perchloric acid fume hoods have special design features. Never heat perchloric acid in a fume hood that has not been designed for this purpose. Restrict use of radioisotopes to fume hoods listed on the approved Radioactive Material Use License.

Laminar Flow Hoods (Clean Benches)

Laminar flow hoods are designed only to protect the product in the hood. Air is pulled into the bottom of the unit, pushed through a HEPA filter, and then out across the bench.

The HEPA filter ensures that air flowing across the workspace is free from particulates or “clean.” The velocity of the outgoing air keeps contaminants from the room from blowing in and settling in the hood. If items are placed in the workspace that can produce aerosols, fumes, or vapors, the air flow pushes these contaminants out toward the user and into the laboratory space.

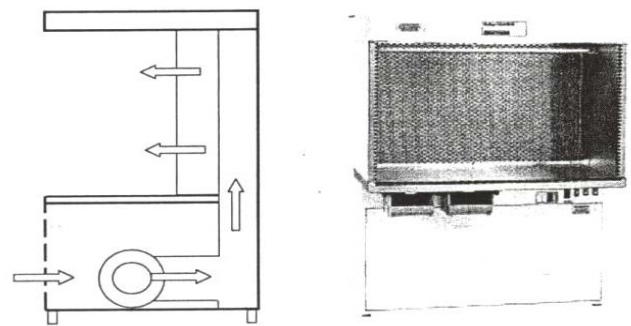

Laminar Flow Hood or Clean Bench

Laminar flow hoods or clean benches are appropriate for pouring plates or use of pathogen free cell culture. They are not designed for use with infectious, chemical, or radiological materials.

Biosafety Cabinets

Most biological safety cabinets (BSC) are designed to protect the research product and the worker from biological materials. Air is pulled into the cabinet through front grill(s) and then moved through the cabinetry of the hood. Air passes through a HEPA filter for product protection and is then pushed downward onto the work surface. Airflow is then split with a fraction of the air exiting through the front grill and the remaining air through the back of the cabinet. (Models differ on the percent of air that is recycled or exhausted). Air that is not recycled is then exhausted through a second HEPA filter into the room or through a stack that vents to the outside of the building.

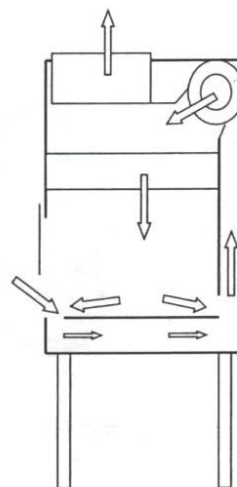

Class II BSC

Biological safety cabinets are appropriate for infectious materials. They are not suitable for chemical and/or radioactive materials unless approved by EHS. Bunsen burners must never be used in a BSC. Because BSCs recycle air, the concentration of gas in the cabinet will accumulate and significantly increase the risk of explosion. In addition, the heat produced by a Bunsen burner creates eddy currents that may disrupt the ordinary air flow and force contaminants back in to the laboratory, exposing workers to infectious materials. See the EHS SOP, **Biosafety Cabinets** for more information.

Glove Box

Glove boxes consist of a sealed chamber with glove ports and gloves for handling materials inside, a viewing window for observing, and transfer chamber or door for loading and unloading. An inert environment can be created in some glove boxes, making them useful for handling air-sensitive materials. Sometimes, glove boxes are used for highly toxic materials because they form a sealed barrier between the chemical and the user. These types of glove boxes are equipped with exhaust filters. Appropriate use depends on the type and design of the glove box. Follow manufacturer's recommendations.

Other Types of Enclosures

Other types of enclosures or ventilation devices may be found in the laboratory setting, such as canopy hoods and ductless carbon-filtered enclosures. These types of devices are intended for very specific applications and do not provide adequate containment/protection for biological, radiological, and chemical laboratory processes.

- **Canopy hoods** are designed to remove steam, heat, or odors generated by specialized equipment such as autoclaves, ovens, steam baths, etc.
- **Ductless carbon-filtered enclosures** are not recommended for general laboratory use. Their principal of operation is based on trapping of chemical fumes and vapors in a filter with air re-circulated back into the work space. They are high maintenance and require frequent filter changes. These types of enclosures are not adequately protective for use with toxic or carcinogenic materials or any chemicals in more than minute quantities. Never use a carbon-filtered enclosure without consulting EHS.
- **Snorkel hoods** are flex ducts that can be positioned as desired. They generally aid in the removal of nuisance odors, heat, and similar uses. These devices are not adequate to provide worker protection from hazardous levels of airborne contaminants. Contact EHS for an exposure assessment if you are using or intend to use a snorkel hood for worker protection purposes.

